

Solderless Breadboards

mbus.net

Power bus
(red)

Ground bus
(blue)

Component
bus

Note that the two
sides are not
connected

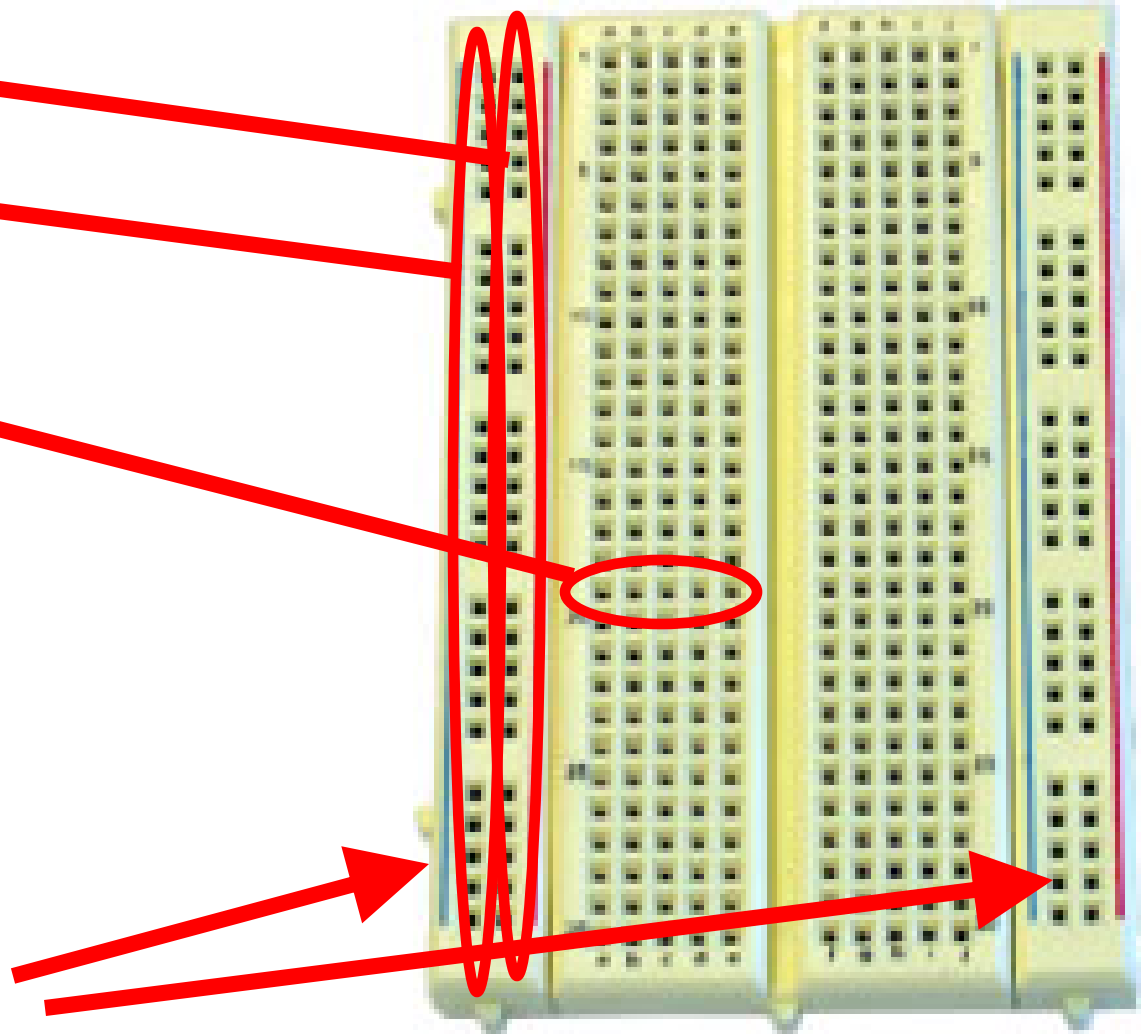

Wiring Standards

When possible, use wire colors for different types of signals:

- Black: ground
- Red: power
- Other: various signals

Clean Wiring

A clean breadboard will make debugging easier – and it makes circuits more robust

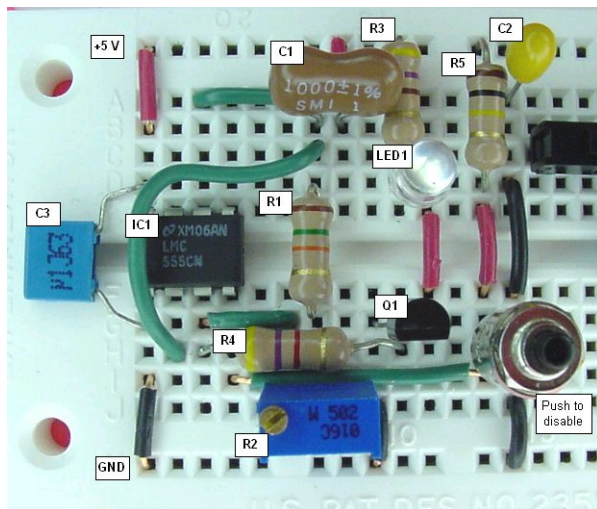

www.linefollowing.com

tangentsoft.net

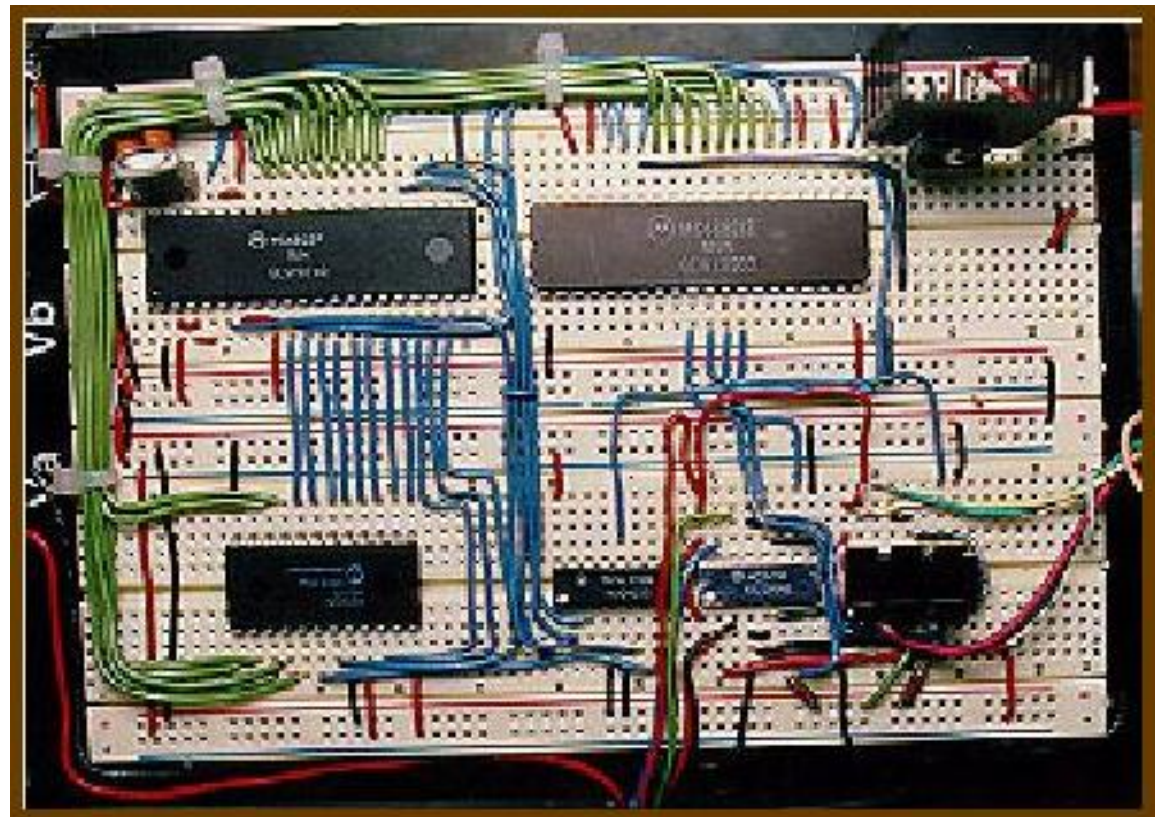

Care with Power

- Only insert components and wires into the breadboard when power is disconnected
- “Wire, check-twice, then power”
 - Never reverse power and ground (this is a very common mistake)
- Most chips that we will use expect +5V
 - More can destroy the chips
 - We will use DC/DC converters to step battery voltages down to +5V

Care of Chips

- Use insertion and extraction tools: never your fingers
- Minimize your contact with pins: static electricity can destroy a chip
- Use a wrist strap when you handle chips

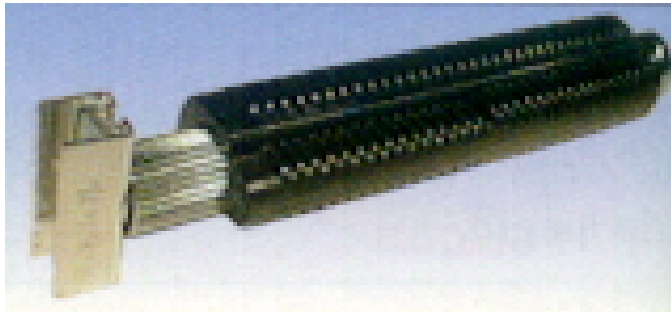

www.chantronics.com.au

www.a7vtroubleshooting.com



www.hvwtech.com

TTL Chips: 2-Input AND Gates

Chip number: 7408

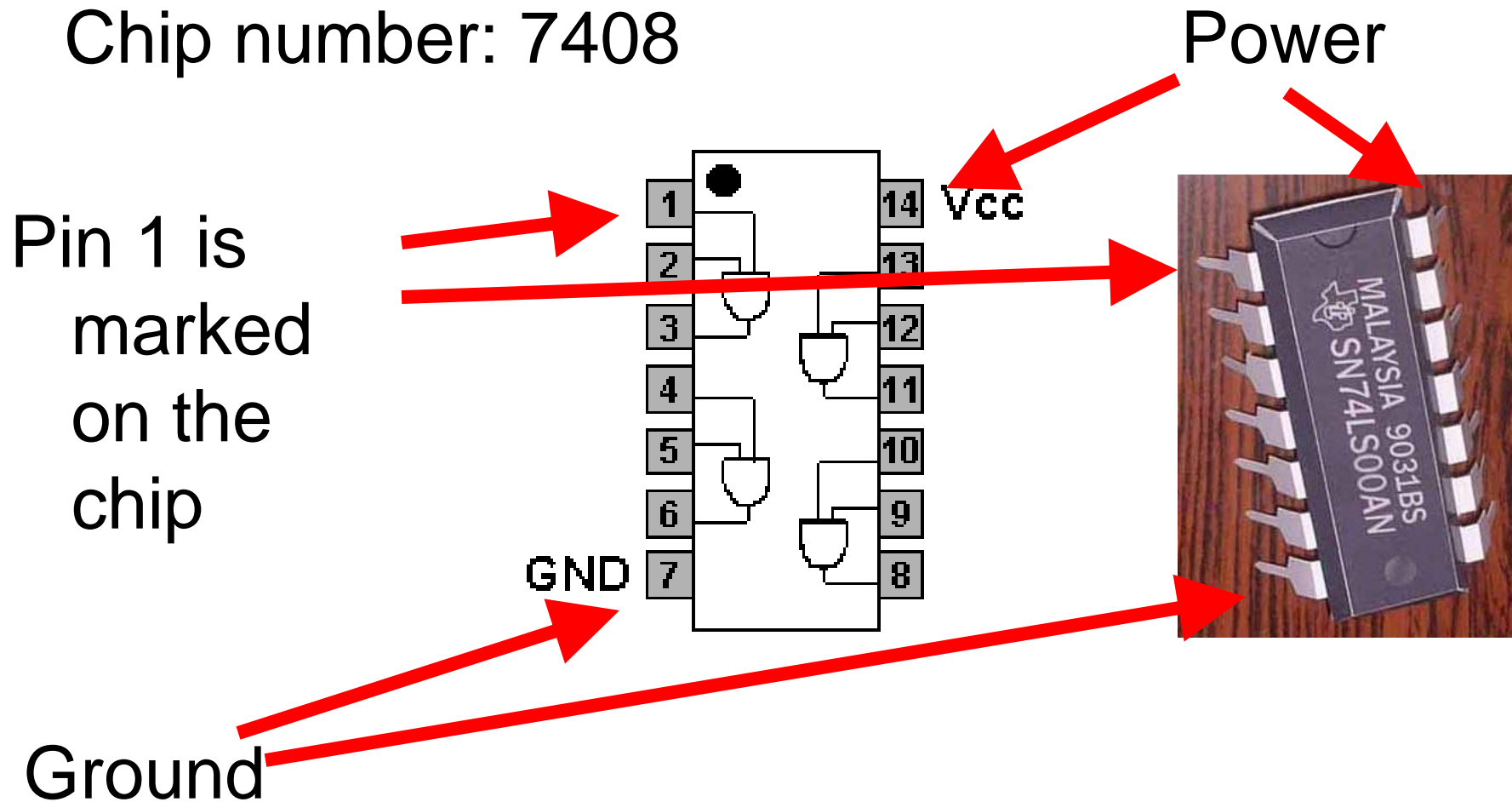

Wiring Procedure (Suggested)

- Power supply
- Power/ground buses
- Insert primary components
- Wire power/ground for components
- Add signals and remaining components
- Test incrementally

Debugging Techniques

- Multimeter:
 - Use *voltage mode* to check logic levels
 - Use *continuity mode* to confirm connections (but never with power turned on!)
- Oscilloscope:
 - View voltage as a function of time on 2 channels
- Test incrementally
- Test intermediate sub-circuits

A Basic Circuit

(Projects 2-4)

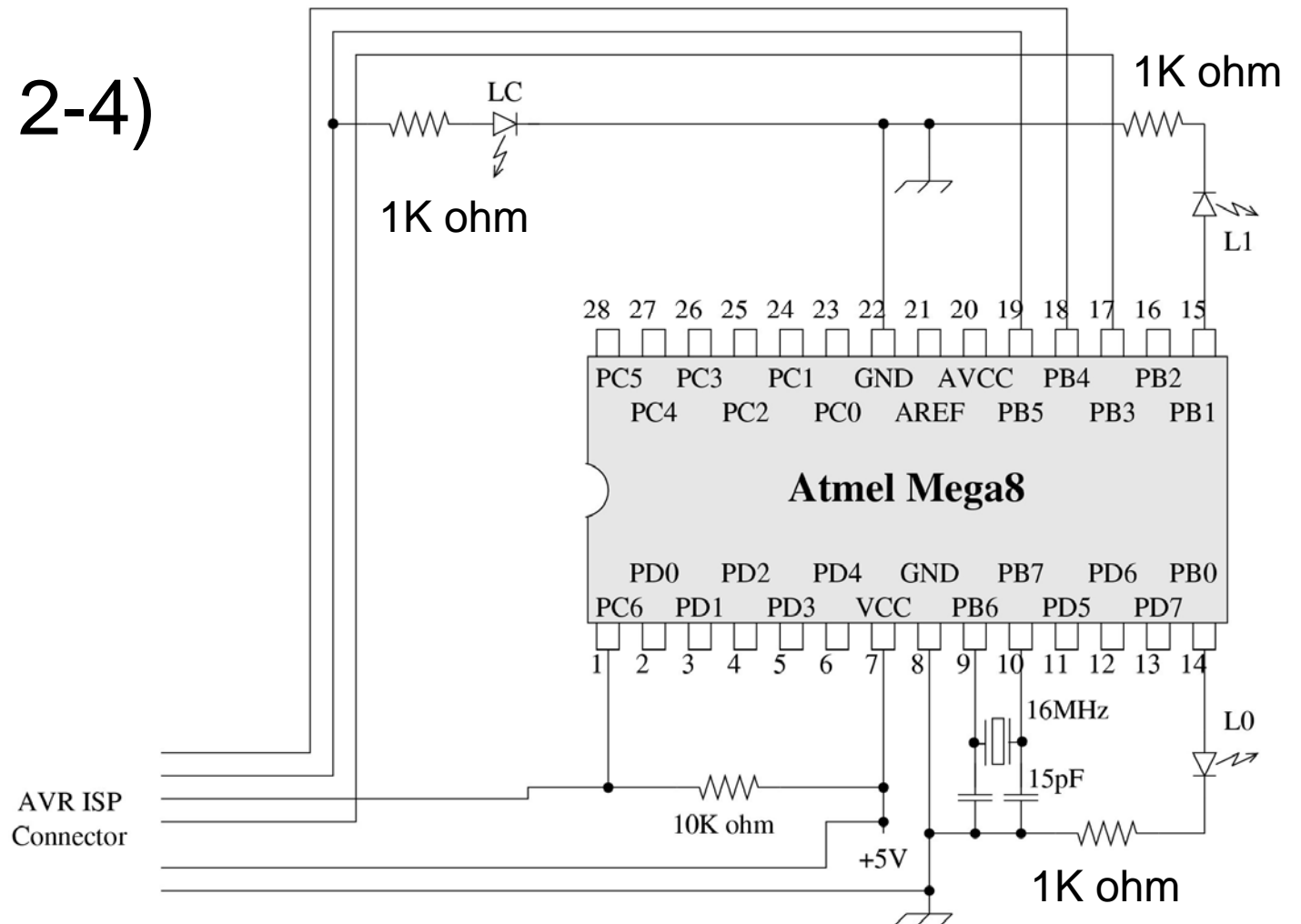

A Basic Circuit

- Connect through adapter to AVR ISP
- Do not reverse the pins!

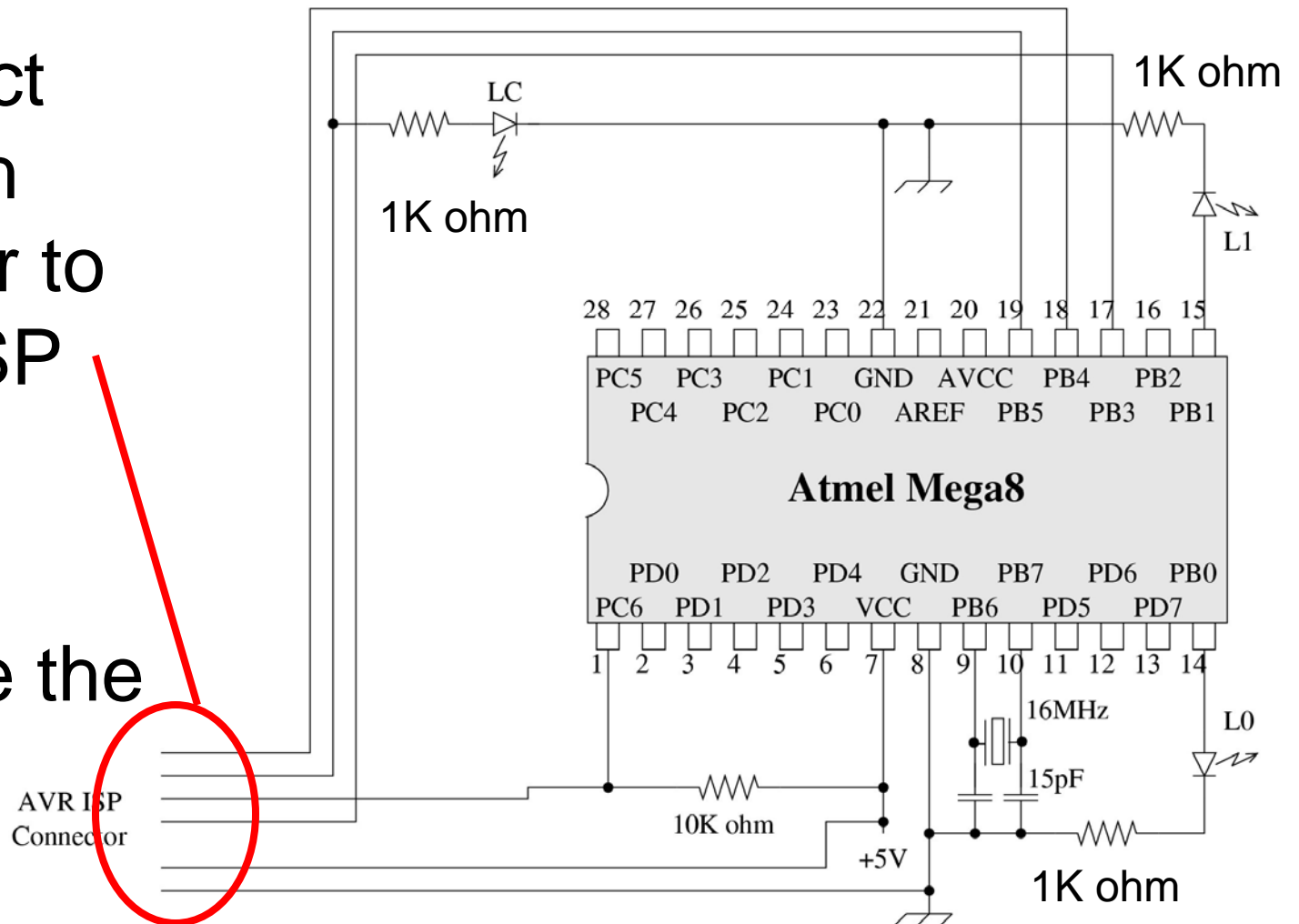

Lab Procedures

- No food or drink are allowed in the lab.
- Before leaving the lab, please be sure to clean up your workspace.
- Because some equipment may be in short supply, please coordinate with others who will need these resources
- Never place dead components back into the stock (instead – place them in the ‘graveyard’)

Lab Procedures

- No equipment or supplies may leave the lab without the permission of the monitor.
- No books may leave the lab.
- Please clear all guests with the lab monitor.
- Unless you have prior permission, please do not handle the projects of other class members.

Lab Procedures

- Always check your wiring before you power up your circuit (especially your power and ground connections).
- When removing chips from breadboards, always use an appropriate tool (not your fingers!).
- If you break something, please report it (don't just put it away).
- You are expected to supply and configure your own laptop computers for project use