

0. Name (2 pts):

---

**AME 3623: Embedded Real-Time Systems**  
**Midterm Exam**  
March 12, 2013

*General instructions:*

- This examination booklet has 9 pages.
- Write your name at the top of the page and sign your name below.
- The exam is closed book, closed notes, and closed electronic device. The exception is that you may have one page of your own notes.
- The exam is worth a total of 100 points (and 10% of your final grade).
- Explain your answers clearly and concisely. Do not write long essays (even if there is a lot of open space on the page). A question worth 5 points is only worth an answer that is at most 2 sentences.
- You have 1.25 hours to complete the exam. Be a smart test taker: if you get stuck on one problem go on to the next. Don't waste your time giving details that the question does not request. Points will be taken off for answers containing excessive or extraneous information.
- Show your work. Partial credit is possible, but only if you show intermediate steps.

Topic	Max	Grade
Name	2	
Number Systems	25	
Analog Processing	30	
Microcontrollers	20	
Digital Input/Output	25	
Total	100	

---

On my honor, I affirm that I have neither given nor received inappropriate aid in the completion of this exam.

**Signature:** \_\_\_\_\_

**Date:** \_\_\_\_\_



- (d) (5 pts) Consider the following number:  $0x38$ . Interpret this as a signed 8-bit integer. What is the negative of this number in binary? Show your work.

- (e) (5 pts) Consider the following code:

```
uint8_t x = 0x21;
uint8_t y;

y = x >> 4;
y = y << 3;
```

What is the value of  $y$  in hexadecimal after the code executes?

2. Analog Processing

(30 pts)

Given the following circuit:

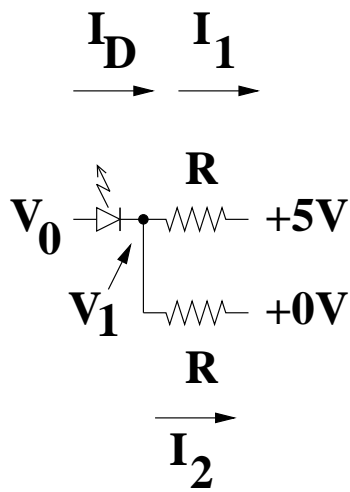

Assume that  $R = 1000\Omega$  and  $V_f = 2V$ .

- (a) (6 pts) What are the equations that are always true?

(b) (12 pts) Assume  $V_0 = 3V$ . What is  $V_1$ ?

(c) (12 pts) Assume  $V_0 = 6V$ . What is  $I_D$ ?

### 3. Microcontrollers

(20 pts)

(a) (8 pts) Give two examples for how the status register is used by other parts of the microprocessor.

(b) (7 pts) When the microprocessor is storing a value into a memory, what two numbers are communicated from the microprocessor to the memory?

(c) (5 pts) True or False, and briefly explain: the following code results in a change in what is stored in the ROM.

```
x = 42;
```

4. Digital Input/Output

(25 pts)

Consider the following circuit diagram:

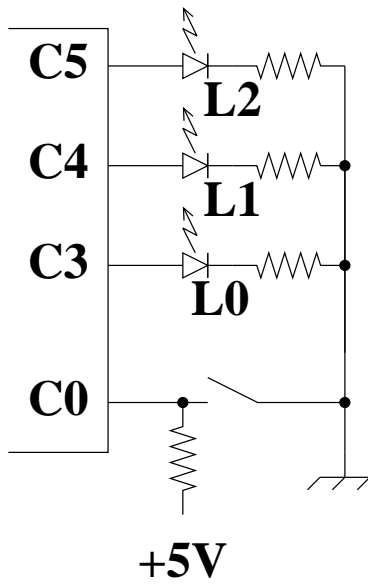

- (a) (5 pts) Given the circuit, how should DDRC be initialized? (there is only one good answer for initialization)

Consider the following code:

```
int main (void)
{
    DDRC = ***; // However you initialized it above.
    PORTC = 0;
    int8_t val = 1;

    while(1) {
        PORTC = (PORTC & 0xE7) | (val << 3);

        if(PINC & 0x1) {
            val ^= 3;
            delay_ms(10);
        } else {
            val -= 1;
            if(val < 0) {
                val = 2;
            }
            delay_ms(100);
        }
    }
}
```

- (b) (10 pts) Explain what happens to the LEDs when the switch is “closed” from the beginning of the program.



- (c) (10 pts) Explain what happens to the LEDs when the switch is “opened” from the beginning of the program.