

AME 3623 Real-Time Embedded Systems
Midterm
March 10, 2016

General instructions:

- Please wait to open this exam booklet until you are told to do so.
- This examination booklet has 8 pages. You also have been issued a bubble sheet.
- Write your name, university ID number and date, and sign your name below. Also, write your name and ID number on your bubble sheet, and fill in the bubbles for your ID.
- The exam is closed book, notes and electronic devices. The exception is that you may have one page of personal notes (double sided).
- The exam is worth a total of 100 points (and 10% of your final grade).
- You have 1.25 hours to complete the exam. Be a smart test taker: if you get stuck on one problem go on to the next.
- Use your bubble sheet to answer all multiple-choice questions. Make sure that the question number and the bubble row number match when you are answering each question.

On my honor, I affirm that I have neither given nor received inappropriate aid in the completion of this exam.

Signature: _____

Name: _____

ID Number: _____

Date: _____

Question	Points	Score
Binary Representations and Mathematical Operators	25	
Circuits	20	
Digital/Analog Systems	15	
Motor Control and Timers	20	
Digital I/O	20	
Total:	100	

C B C C B A B

Part I. Binary Representations and Mathematical Operators

1. (4 points) What is the decimal representation for the binary digits 1000 1001? Assume a signed, 8-bit integer.

A. **-119** B. -9 C. -8 D. 137 E. Answer not shown

2. (5 points) What is the decimal value of c after the following code is executed?

```
uint8_t a = 7;
uint8_t b = 10;
uint8_t c = a && b
```

A. 0 B. **1** C. 2 D. 15 E. Answer not shown

3. (4 points) What is the binary representation of a after the following code is executed?

```
uint8_t a = 0x52;
```

A. 0011 0010 B. 0011 0100 C. **0101 0010** D. 0101 0100
E. Answer not shown

4. (4 points) What is the decimal representation of b after the following code is executed?

```
uint8_t a = 32;
uint8_t b = (a/17)<<5;
```

A. 0 B. 16 C. **32** D. 60 E. Answer not shown

5. (4 points) What is the hexadecimal representation of c after the following code is executed?

```
uint8_t a = 0x33;
uint8_t b = 0xA5;
uint8_t c = a ^ b;
```

A. 0x0 B. 0x21 C. 0x97 D. 0xB7 E. **Answer not shown**

6. (4 points) What is the binary representation of b after the following code is executed?

```
uint8_t a = 67;  
uint8_t b = a | (1<<3) | (1<<7);
```

- A. 0100 0011 B. 0100 1011 C. 0110 0111 **D. 1100 1011**
E. Answer not shown

Part II. Circuits

Consider the following circuit:

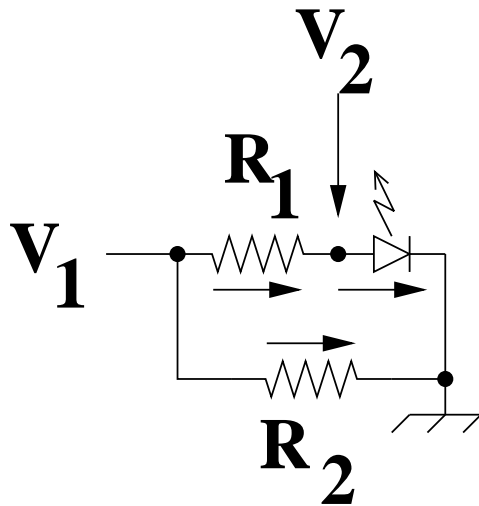

Assume $R_1 = 100\Omega$, $R_2 = 1000\Omega$ and $V_f = 3V$.

7. (5 points) Given that $V_1 = 4V$. What is I_D ?
A. 0 mA B. 6 mA C. 10 mA D. 14 mA E. Answer not shown

8. (5 points) Given that $V_1 = 2V$. What is V_2 ?
A. 0 V B. 2 V C. 3 V D. 5 V E. Answer not shown

Consider the following circuit:

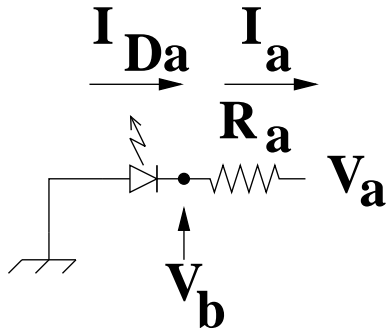

Assume $R_a = 200\Omega$ and $V_{fa} = 1V$.

9. (5 points) Given that $V_a = 5V$ What is I_{Da} ?
A. 0 mA B. 5 mA C. 20 mA D. 25 mA E. Answer not shown
10. (5 points) Given that $V_a = -6V$ What is V_b ?
A. -6 V B. -5 V C. -1 V D. 0 V E. Answer not shown

Part III. Digital/Analog Systems

11. (5 points) Assume an 8-bit analog-to-digital converter that uses the successive approximation algorithm, and has a range of 0 to 5 volts. If $V_{in} = 3V = 153/51 V$ and the first guess by successive approximation is 1000 0000, what is the third guess?
A. 1000 0000 B. 1001 0000 C. 1001 1000 **D. 1010 0000**
E. Answer not shown
12. (5 points) Assume a 4-bit analog-to-digital converter that uses the successive approximation algorithm, and has a range of 0 to 15 volts. What is the binary value that corresponds to $V_{in} = 7.5V$?
A. 0000 0111 B. 0000 1111 C. 0111 1111 D. 1111 1111
E. Answer not shown
13. (5 points) Assume an 8-bit analog-to-digital converter that uses the successive approximation algorithm, and has a range of 0 to 5 volts. What is the digital representation of $V_{in} = 4.5V = 229.5/51 V$ in binary?
A. 0111 0010 B. 0111 0011 **C. 1110 0101** D. 1110 0110
E. Answer not shown

Part IV. Motor Control and Timers

Consider the following circuit:

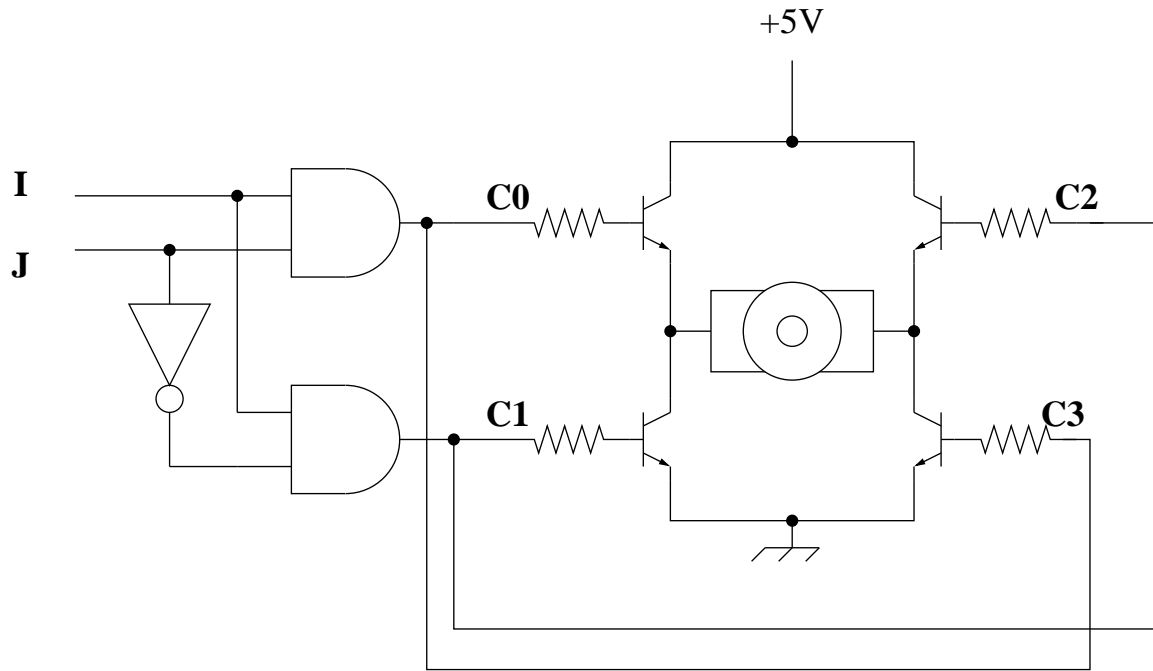

14. (5 points) When $I = 0$ and $J = 1$, what happens to the motor?
 - A. A short circuit occurs
 - B. A torque is generated
 - C. No torque is generated**
 - D. The motor dynamically brakes
 - E. Answer not shown

15. (5 points) Which input should be used as the torque magnitude signal?
 - A. I**
 - B. J
 - C. Answer not shown

16. (5 points) Assume Timer 5 and a prescaler of 8. How long does it take for the counter to reach 10,000 from 0?
 - A. 0.625 ms
 - B. 5 ms**
 - C. 40 ms
 - D. 320 ms
 - E. Answer not shown

17. (5 points) When $I = 1$ and $J = 1$, what happens to the motor?
 - A. A short circuit occurs
 - B. A torque is generated**
 - C. No torque is generated
 - D. The motor dynamically brakes
 - E. Answer not shown

Part V. Digital I/O

Consider the following circuit and code:

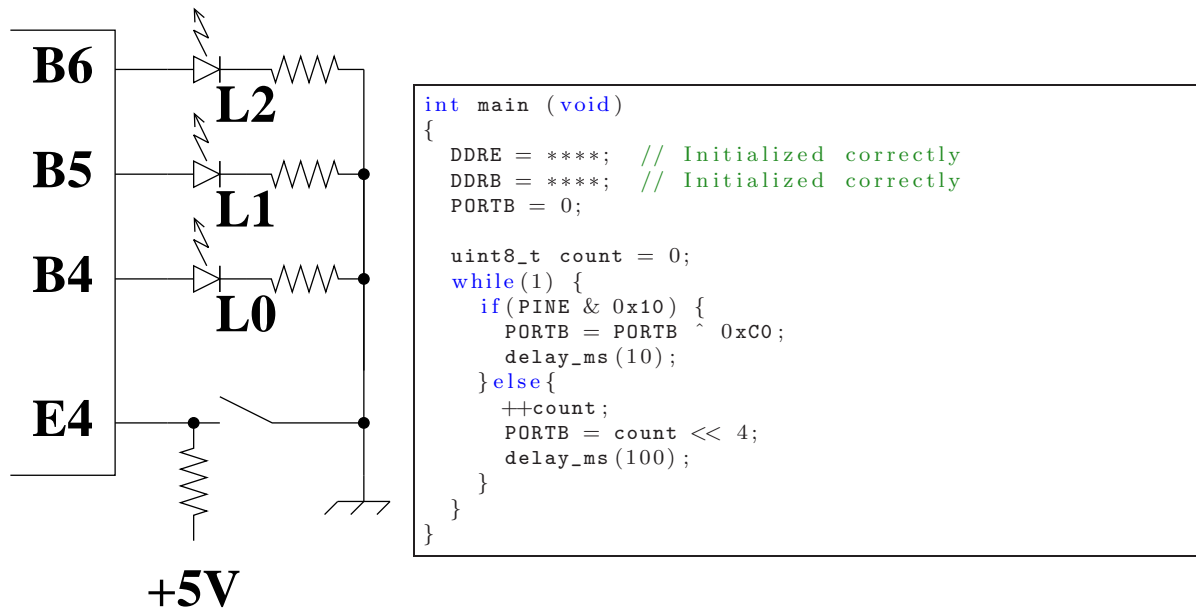

18. (5 points) What is the correct initialization for DDRE given the circuit?
 - A. $0x0$ B. $0x70$ C. $0xE0$ D. $0xFF$ E. Answer not shown

19. (5 points) When the switch is open, at what frequencies do L_2 and L_1 pulse? Only consider sustained pulsing.
 - A. **50 Hz and not-at-all, respectively**
 - B. 100 Hz and not-at-all
 - C. 50 Hz and 50 Hz
 - D. 100 Hz and 100 Hz
 - E. Answer not shown

20. (5 points) What is the correct initialization for DDRB given the circuit?
 - A. $0x0$ **B. $0x70$** C. $0xE0$ D. $0xFF$ E. Answer not shown

21. (5 points) When the switch is closed, at what frequencies do L_1 and L_0 pulse? Only consider sustained pulsing.
 - A. 2.5 Hz and 2.5 Hz, respectively
 - B. 2.5 Hz and 5 Hz**
 - C. 5 Hz and 5 Hz
 - D. 5 Hz and 10 Hz
 - E. Answer not shown