

AME 3623 Real-Time Embedded Systems
Final Exam
May 10, 2016

General instructions:

- Please wait to open this exam booklet until you are told to do so.
- This examination booklet has 14 pages. You also have been issued a bubble sheet.
- Write your name, university ID number and date below, and sign where indicated. Also, write your name and ID number on your bubble sheet, and fill in the bubbles for your ID. C B B
- The exam is closed book, notes and electronic devices. The exception is that you may have one page of personal notes (double sided).
- The exam is worth a total of 200 points (and 20% of your final grade).
- You have 2 hours to complete the exam. Be a smart test taker: if you get stuck on one problem go on to the next.
- Use your bubble sheet to answer all multiple-choice questions. Make sure that the question number and the bubble row number match when you are answering each question. B C C A

On my honor, I affirm that I have neither given nor received inappropriate aid in the completion of this exam.

Signature: _____

Name: _____

ID Number: _____

Date: _____

Question	Points	Score
Number Representations and Operations	40	
Circuits and Code	60	
Control	20	
Interrupt Service Routines and Timer/Counters	25	
Serial Processing	15	
Finite State Machines	40	
Total:	200	

Part I. Number Representations and Operations

- (5 points) What is the maximum value that can be represented with a **signed**, “5.3” fixed-point number?
A. $3\frac{63}{64}$ B. $7\frac{63}{64}$ C. $15\frac{7}{8}$ D. $31\frac{7}{8}$ E. Answer not shown
- (5 points) What is the fixed-point representation of $2\frac{3}{8}$ using “12.4” fixed-point?
A. 2 B. 9 C. 19 **D. 38** E. Answer not shown
- (5 points) What is the binary representation of a after the following code is executed?

```
uint8_t a = 0xA5;
```

- A. **1010 0101** B. 1010 1001 C. 1100 0101 D. 1100 1001
E. Answer not shown
- (5 points) What is the hexadecimal representation of b after the following code is executed?

```
uint8_t a = 0x25;  
uint8_t b = a + 23;
```

- A. 0x30 **B. 0x3C** C. 0x48 D. 0x72 E. Answer not shown
- (5 points) What is the binary representation for -42? Assume a signed, 8-bit integer.
A. 0010 1010 B. 1011 1110 C. 1101 0101 **D. 1101 0110**
E. Answer not shown
 - (5 points) What is the decimal representation of b after the following code is executed?

```
uint8_t a = 20;  
uint8_t b = 14 * (a/7);
```

- A. 0 B. 14 C. 40 D. 42 **E. Answer not shown**

Solution: 28

7. (5 points) What is the hexadecimal representation of c after the following code is executed?

```
uint8_t a = 0x25;
uint8_t b = 0x26;
uint8_t c = (a >> 4) | b;
```

A. **0x26** B. 0x27 C. 0x28 D. 0x4B E. Answer not shown

8. (5 points) What is the decimal value of c after the following code is executed? Assume a “6.2” fixed-point representation.

```
uint8_t a = 6;
uint8_t b = 10;
uint8_t c = fixed_point_mul(a, b);
```

A. 7 B. **15** C. 60 D. 240 E. Answer not shown

Part II. Circuits and Code

Consider the following circuit and associated code:

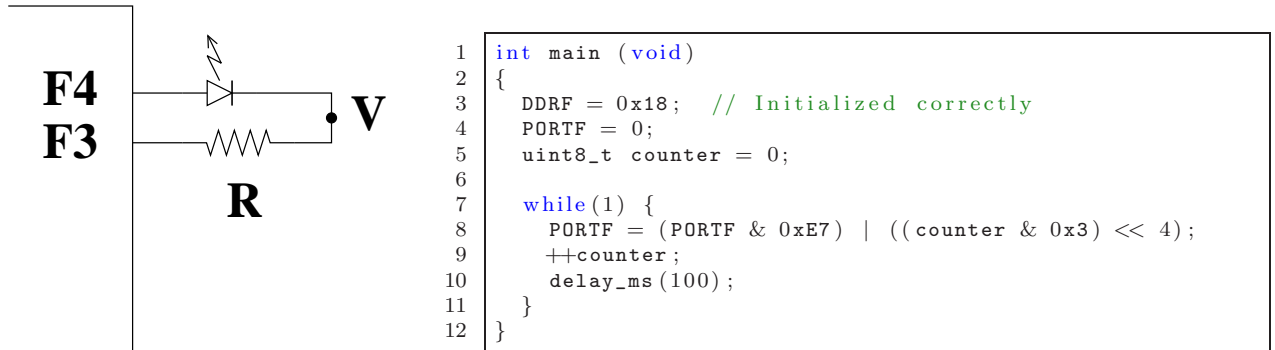

Assume $R = 400\Omega$, $V_f = 1V$ and the maximum voltage output from a microprocessor pin is $5V$.

9. (5 points) When $counter = 2$ on line 8, what is V ?
A. $0V$ B. $2V$ C. $3V$ D. $5V$ E. Answer not shown
10. (5 points) When $counter = 7$ on line 8, what is I_D ?
A. 0 mA B. 2.5 mA C. 10 mA D. 12.5 mA E. Answer not shown
11. (5 points) What is the duty cycle of the LED flash?
A. 0% B. 25% C. 50% D. 100% E. Answer not shown
12. (5 points) What is the frequency of the LED flash?
A. 0 Hz (no flashing) B. 2.5 Hz C. 5 Hz D. 10 Hz
E. Answer not shown

Consider the following circuit:

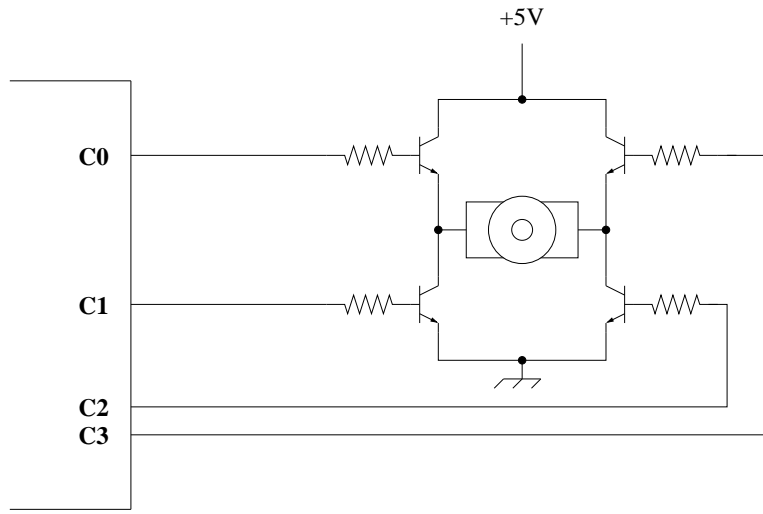

Assume that $DDRC = 0xF$.

13. (5 points) What is the best description of what happens when $PORTC = 0xA$?
 - A. The motor dynamically brakes
 - B. The motor produces no torque
 - C. The motor produces a torque**
 - D. There is a short circuit
 - E. Answer not shown

14. (5 points) What is the best description of what happens when $PORTC = 0x8$?
 - A. The motor dynamically brakes
 - B. The motor produces no torque**
 - C. The motor produces a torque
 - D. There is a short circuit
 - E. Answer not shown

15. (5 points) What is the best description of what happens when $PORTC = 0x9$?
 - A. The motor dynamically brakes**
 - B. The motor produces no torque
 - C. The motor produces a torque
 - D. There is a short circuit
 - E. Answer not shown

16. (5 points) What is the best description of what happens when $PORTC = 0x7$?
 - A. The motor dynamically brakes
 - B. The motor produces no torque
 - C. The motor produces a torque
 - D. There is a short circuit**
 - E. Answer not shown

Consider the following circuit:

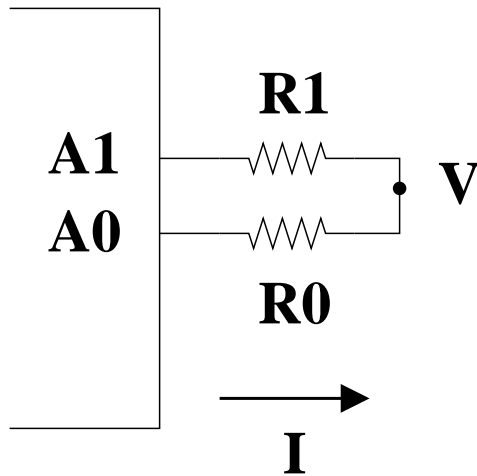

Assume $R_0 = 500\Omega$, $R_1 = 1000\Omega$ and the maximum voltage output from a microprocessor pin is $5V$.

17. (5 points) What is the correct initialization for $DDRA$?
A. $0x0$ B. $0x03$ C. $0x0F$ D. $0xFF$ E. Answer not shown

18. (5 points) If $PORTA = 0x42$, what is V ?
A. $0V$ B. $5/3V$ C. $10/3V$ D. $5V$ E. Answer not shown

19. (5 points) If $PORTA = 0x5C$, what is V ?
A. $0V$ B. $5/3V$ C. $10/3V$ D. $5V$ E. Answer not shown

20. (5 points) If $PORTA = 0xDD$, what is V ?
A. $0V$ B. $5/3V$ C. $10/3V$ D. $5V$ E. Answer not shown

Part III. Control

Consider the following rotational P-D control law:

$$\tau = K_p(\theta_d - \theta) + K_v\dot{\theta}$$

Assume that positive orientation and torque both refer to the same direction.

21. (5 points) Assume $K_v = 0$. If one made the incorrect choice of sign for K_p , what would happen in all cases? You may assume that wrap-around is handled appropriately.
- A. $|\dot{\theta}|$ would decrease B. $|\dot{\theta}|$ would increase
C. $|\theta_d - \theta|$ would be small on average **D. $|\theta_d - \theta|$ would be large on average**
E. Answer not shown
22. (5 points) In order to achieve critical damping, what is the sign of K_p ?
- A. $K_p > 0$** B. $K_p < 0$
23. (5 points) Suppose that a linear plant (an object being controlled) is exhibiting an overdamped behavior. How could you change the control parameters to address this problem? (note that sign matters here)
- A. Decrease K_p or decrease K_v B. Decrease K_p or increase K_v
C. Increase K_p or decrease K_v **D. Increase K_p or increase K_v**
E. Answer not shown
24. (5 points) In order to achieve critical damping, what is the sign of K_v ?
- A. $K_v > 0$ **B. $K_v < 0$**

Part IV. Interrupt Service Routines and Timer/Counters

Carefully consider the following circuit and code:

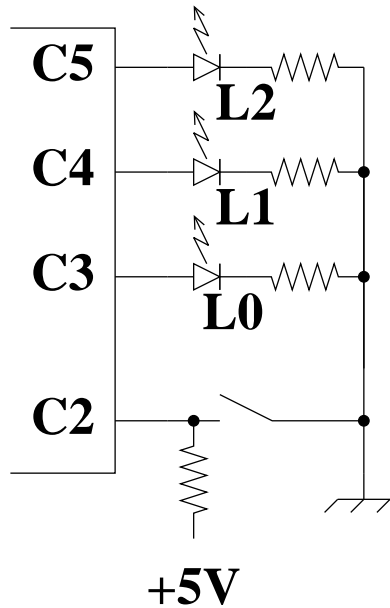

```

volatile uint8_t x;

ISR(TIMER5_OVF_vect) {
    static uint8_t counter = 0;

    if(counter == 6) {
        PORTC |= 0x8;
    } else {
        PORTC &= 0xF7;
    }
    counter++;
}

int main(void) {
    DDRC = **correct initialization**;;
    PORTC = 0;

    x = 5;

    timer5_config(TIMER5_PRE_1024);
    timer5_enable();
    sei();

    while(1) {
    }
}

```

25. (5 points) What is the correct initialization for *DDRC*?
 A. $0x4$ B. $0x38$ C. $0x3C$ D. $0x70$ E. Answer not shown

26. (5 points) At what frequency are the interrupts being generated?
 A. $\frac{16,000,000}{256^2}$ B. $\frac{16,000,000}{256^3}$ C. $\frac{16,000,000}{1024 \times 256}$ D. $\frac{16,000,000}{1024 \times 256^2}$
 E. Answer not shown

27. (5 points) At what duty cycle is *L1* flashing?
 A. 0% (not flashing) B. 25% C. 50% D. 100% E. Answer not shown

28. (5 points) At what duty cycle is *L0* flashing?
 A. 0% (not flashing) B. 25% C. 50% D. 100% E. Answer not shown

Solution: The LED is turned on one count out of 256. So, the duty cycle is:
 $\frac{100}{256}\%$

29. (5 points) At what frequency is *L0* flashing?

- A. $\frac{16,000,000}{256^3}$ B. $\frac{16,000,000}{1024 \times 256}$ C. $\frac{16,000,000}{1024 \times 256^3}$ D. $\frac{16,000,000}{1024 \times 256^4}$
E. Answer not shown

Part V. Serial Processing

30. (15 points) Fill in the implementation of the following function that takes as input a character representing a hexadecimal digit and returns the integer value of that digit. If the character is not a valid hexadecimal digit, then the function returns -1 .

```
int8_t char2value(char c) {
```

```
}
```

Solution:

```
int8_t char2value(char c) {  
    if(c >= '0' && c <= '9'){  
        return c-'0';  
    }else if(c >= 'a' && c <= 'f') {  
        return c-'a'+10;  
    }else if(c >= 'A' && c <= 'F') {  
        return c-'A'+10;  
    }else{  
        return -1;  
    }  
}
```

Part VI. Finite State Machines

31. (20 points) Consider the problem of a robot dribbling a ball down a soccer field until the ball reaches the goal. The robot is equipped with a camera that will automatically move to follow the ball if it sees it. We will design a FSM that performs the high level control for this robot.

The actions are as follows:

- Look for ball (LOOK). This is an action that initiates a visual search for the ball that will eventually succeed.
- Move toward a location behind ball (BEHIND): the robot drives in a straight line toward some position such that the ball is between the robot and the goal
- Approach ball (APPROACH): the robot drives to within kicking distance of the ball
- Kick the ball forward (KICK)
- CELEBRATE

The events are:

- BALL: the camera sees the ball
- NO_BALL: the camera does not see the ball
- NEAR: the robot is within kicking distance of the ball
- GOAL: the ball is at the goal
- NOT_GOAL: the ball is not at the goal
- LINED_UP: the ball is between the robot and the goal

Note 1: Although the camera will move to try to keep the ball in view, it can lose visual track of the ball. The FSM must take this into account by initiating a new search.

Note 2: You may assume that there are no other agents on the field. Hence, the ball only moves when kicked by the robot. Furthermore, you may assume that any time that robot perceives the ball's location, the ball is not in motion (i.e., it won't change location again until it is kicked).

Draw the FSM that will result in the ball arriving at the goal and the robot celebrating this fact

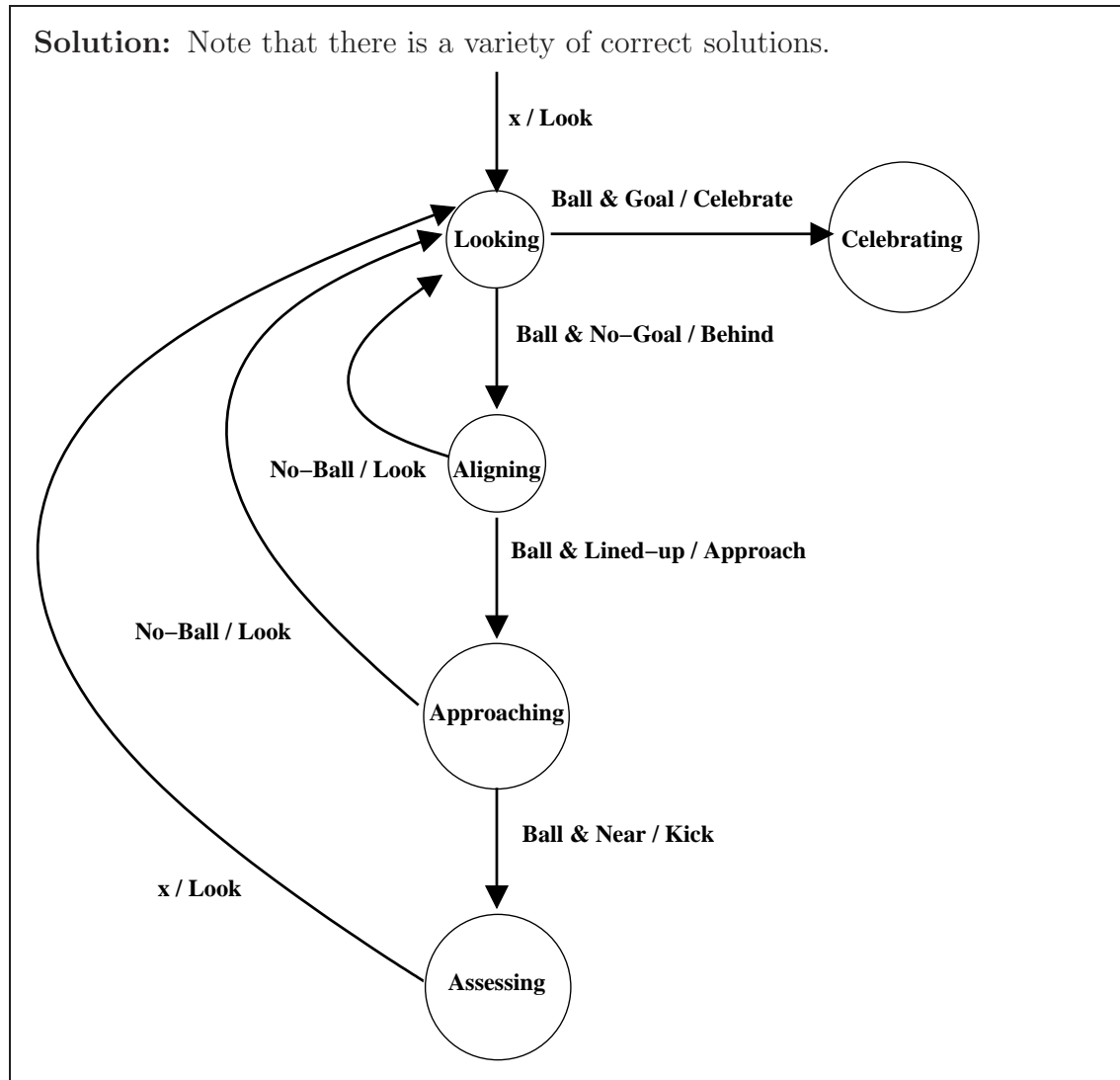

32. (20 points) Consider a FSM whose state is described by a 3-bit two's complement binary number (i.e., there are 2^3 states). This finite state machine has two possible events: negate (NEG) (take the two's complement negation of the number) and add 3 to the number (ADD). For the latter event, we assume that the number is unsigned and that higher order bits (bits 4 and higher) are dropped after the addition.

Draw the FSM diagram that describes the behavior of this device when the different events occur (don't worry about actions in this case).

