

AME 3623 Real-Time Embedded Systems  
Final Exam  
May 11, 2017

General instructions:

- Please wait to open this exam booklet until you are told to do so.
- This examination booklet has 14 pages. You also have been issued a bubble sheet.
- Write your name, university ID number and date below, and sign where indicated. Also, write your name and ID number on your bubble sheet, and fill in the bubbles for your ID. C B
- The exam is closed book, notes and electronic devices. The exception is that you may have one page of personal notes (double sided).
- The exam is worth a total of 274 points (and 20% of your final grade).
- You have 2 hours to complete the exam. Be a smart test taker: if you get stuck on one problem go on to the next.
- Use your bubble sheet to answer all multiple-choice questions. Make sure that the question number and the bubble row number match when you are answering each question. Use the provided space in this exam booklet to answer the FSM drawing questions. B C C A C

On my honor, I affirm that I have neither given nor received inappropriate aid in the completion of this exam.

**Signature:** \_\_\_\_\_ **Name:** \_\_\_\_\_

**ID Number:** \_\_\_\_\_ **Date:** \_\_\_\_\_

Question	Points	Score
Number Representations and Operations	45	
Circuits	42	
Circuits and Code	61	
Control	32	
Interrupt Service Routines	23	
Serial Processing	21	
Finite State Machines	50	
Total:	274	

Part I. Number Representations and Operations

- (5 points) What is the maximum value that can be represented with an **unsigned**, “5.3” fixed-point number?  
A.  $7\frac{15}{16}$    B.  $15\frac{15}{16}$    C.  $15\frac{7}{8}$    **D.  $31\frac{7}{8}$**    E. Answer not shown
- (5 points) What is the decimal value of  $c$  after the following code is executed? Assume a “6.2” fixed-point representation.

```
uint8_t a = 6;  
uint8_t b = 10;  
uint8_t c = fixed_point_div(a, b);
```

- A. 0   B. 1   **C. 2**   D. 60   E. Answer not shown
- (5 points) What is the fixed-point representation of 6.5 using “13.3” fixed-point?  
A. 6   **B. 52**   C. 53   D. 65   E. Answer not shown
  - (5 points) What is the binary representation of  $a$  after the following code is executed?

```
uint8_t a = 0xD3;
```

- A. 1100 0011   **B. 1101 0011**   C. 1100 0110   D. 1101 0110  
E. Answer not shown
- (5 points) What is the binary representation for -0x42? Assume a signed, 8-bit integer.  
A. 0100 0010   B. 0010 1010   **C. 1011 1110**   D. 1101 0101  
E. Answer not shown
  - (5 points) What is the decimal representation of  $b$  after the following code is executed?

```
uint8_t a = 20;  
uint8_t b = 14 * a / 3;
```

- A. 80   B. 84   **C. 93**   D. 93.3333...   E. Answer not shown

7. (5 points) What is the decimal value of  $c$  after the following code is executed? Assume a “12.4” fixed-point representation.

```
uint16_t a = 23;
uint16_t b = 13;
uint16_t c = fixed_point_add(a, b);
```

- A. 2    B. 32    C. **36**    D. 576    E. Answer not shown
8. (5 points) What is the binary representation for  $b$  after the following code is executed?

```
int8_t a = 27;
int8_t b = a - 42;
```

- A. 0000 1111    B. 0001 1011    C. 1111 0000    D. **1111 0001**  
E. Answer not shown
9. (5 points) What is the hexadecimal representation of  $c$  after the following code is executed?

```
uint8_t a = 0x25;
uint8_t b = 0x26;
uint8_t c = (a ^ 9) | b; // XOR
```

- A. 0x27    B. 0x28    C. **0x2E**    D. 0x2F    E. Answer not shown

Part II. Circuits

10. (6 points) Given the following circuit and  $R = 100\Omega$ ,  $V_1 = 3V$  and  $I = 60mA$ . What is  $V_2$ ?

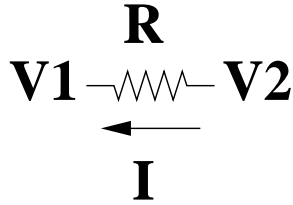

- A.  $-3V$    B.  $0V$    C.  $3V$    D.  $9V$    E. Answer not shown

Consider the following circuit:

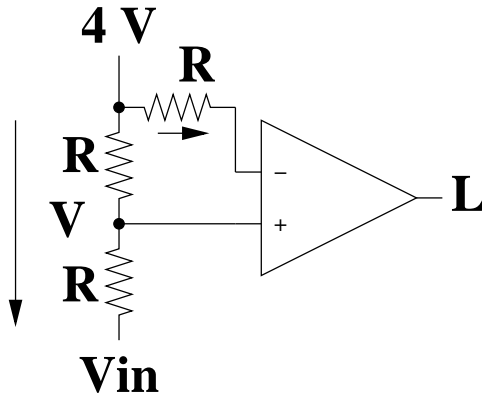

Assume that  $R = 600\Omega$  and that  $L$  is a logical output.

11. (8 points) If  $V_{in} = 7V$ , what is  $V$ ?  
 A.  $3.5V$    B.  $4V$    C.  $5.5V$    D.  $7V$    E. Answer not shown
12. (8 points) If  $V_{in} = 6V$ , what is  $L$ ?  
 A. **True**   B. False   C. Answer not shown
13. (8 points) If  $V_{in} = 3V$ , what is  $L$ ?  
 A. True   B. **False**   C. Answer not shown

Consider the following circuit:

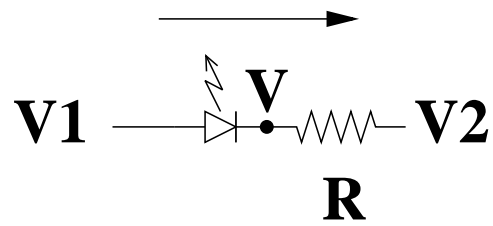

Assume that  $V_f = 2V$  and  $R = 1000\Omega$ .

14. (6 points) If  $V_1 = 0V$ ,  $V_2 = 4V$ , what is  $I_D$ ?  
A.  $-4mA$    B.  $0mA$    C.  $2mA$    D.  $4mA$    E. Answer not shown
15. (6 points) If  $V_1 = 6V$ ,  $V_2 = 1V$ , what is  $V$ ?  
A.  $1V$    B.  $2V$    C.  $4V$    D.  $6V$    E. Answer not shown

Part III. Circuits and Code

Consider the following circuit:

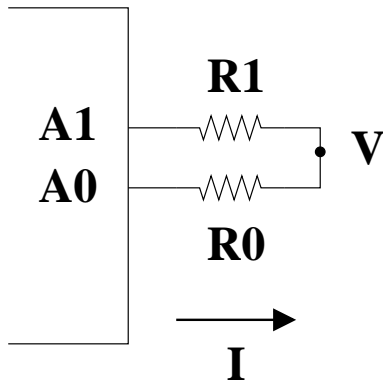

Assume  $R_0 = 1500\Omega$ ,  $R_1 = 500\Omega$  and the maximum voltage output by a microprocessor pin is  $5V$ .

16. (5 points) What is the correct initialization for *PORTA\_PDDR*?  
 A.  $0x0$     **B.  $0x03$**     C.  $0x0F$     D.  $0xFF$     E. Answer not shown
  
17. (8 points) If *PORTA\_PDOR* =  $0x46$ , what is  $V$ ?  
 A.  $0V$     B.  $1.66\dots V$     C.  $3.33\dots V$     **D.  $3.75V$**     E. Answer not shown
  
18. (8 points) If *PORTA\_PDOR* =  $0xA8$ , what is  $V$ ?  
**A.  $0V$**     B.  $1.66\dots V$     C.  $3.33\dots V$     D.  $3.75V$     E. Answer not shown
  
19. (8 points) If *PORTA\_PDOR* =  $0x25$ , what is  $V$ ?  
 A.  $0V$     B.  $1.66\dots V$     C.  $3.33\dots V$     D.  $3.75V$     **E. Answer not shown**
  
20. (8 points) Assume an 8-bit analog-to-digital converter that uses the successive approximation algorithm, and has a range of 0 to 5 volts. If  $V_{in} = 1.5V$  and the first guess by successive approximation is 1000 0000, what is the third guess?  
 A. 0100 0000    **B. 0110 0000**    C. 1100 0000    D. 1110 0000  
 E. Answer not shown

Consider the following circuit:

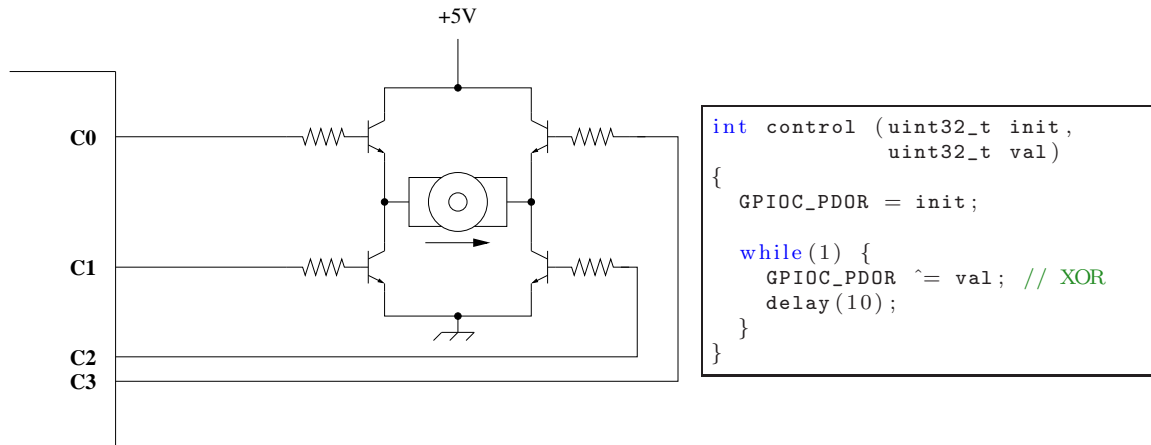

Assume that Port C, pins 0..3 are configured as digital output pins. Also assume that the motor can be modeled as a  $1\Omega$  resistor.

21. (6 points) When  $init = 0x5$  and  $val = 0x0$ , what is the duty cycle of the signal on  $C0$ ?  
 A. 0%   B. 25%   C. 50%   **D. 100%**   E. Answer not shown
22. (6 points) When  $init = 0x5$  and  $val = 0x0$ , what is the average current through the motor?  
 A.  $-2.5 A$    B.  $0 A$    C.  $2.5 A$    **D.  $5.0 A$**    E. Answer not shown
23. (6 points) When  $init = 0xA$  and  $val = 0xA$ , what is the average current through the motor?  
**A.  $-2.5 A$**    B.  $0 A$    C.  $2.5 A$    D.  $5.0 A$    E. Answer not shown
24. (6 points) When  $init = 0x5$  and  $val = 0xF$ , what is the average current through the motor?  
 A.  $-2.5 A$    **B.  $0 A$**    C.  $2.5 A$    D.  $5.0 A$    E. Answer not shown

Part IV. Control

Consider the following rotational P-D control law:

$$\tau = K_p(\theta - \theta_d) + K_v(\dot{\theta} - \dot{\theta}_d)$$

Assume that positive orientation and torque both refer to the same direction.

25. (5 points) The full  $K_v$  term in the control equation can best be described physically as:  
A. a spring    B. a velocity    C. a position    **D. friction**    E. Answer not shown
26. (5 points) In order to achieve critical damping, what is the sign of  $K_p$ ?  
A.  $K_p > 0$     **B.  $K_p < 0$**
27. (5 points) The region around zero rotational error around which we consider the orientation to be “good enough” and do not produce a correcting torque is referred to as:  
A. the critical region    B. the damping region    **C. the deadband region**  
D. the saturation region    E. Answer not shown



Consider the two phase diagrams:

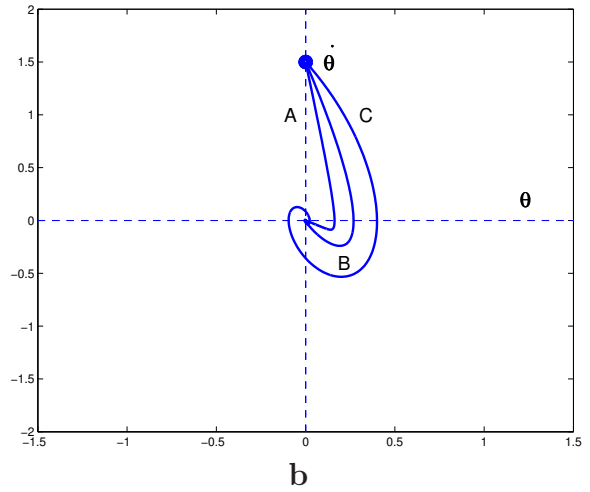
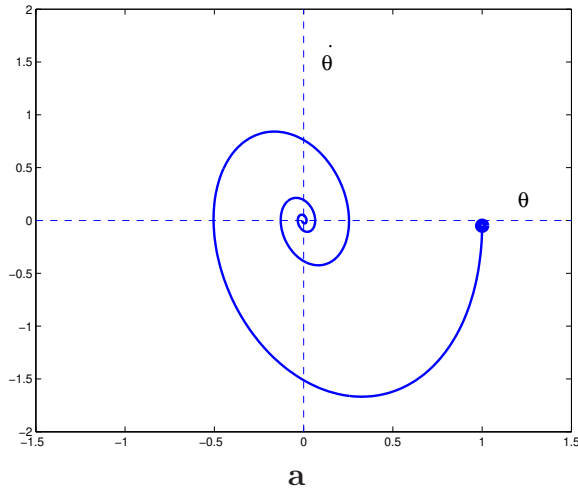

Note: assume the control equations on the previous page and that  $\dot{\theta}_d = 0$  for all time. Also assume that the initial configuration corresponds to the large, filled dot.

28. (6 points) In phase diagram **b**, which path is closest to being critically damped?  
 A. A    **B. B**    C. C
29. (6 points) In phase diagram **a**, what can be changed in order to improve the performance of the system?  
 A.  $K_p$  can be decreased or  $K_v$  can be decreased.  
**B.  $K_p$  can be decreased or  $K_v$  can be increased.**  
 C.  $K_p$  can be increased or  $K_v$  can be decreased.  
 D.  $K_p$  can be increased or  $K_v$  can be increased.  
 E. Answer not shown.
30. (5 points) In phase diagram **a**, the system is:  
 A. Critically damped    B. Over-damped    **C. Under-damped**

## Part V. Interrupt Service Routines

Consider the following code:

```
volatile uint8_t x = 0;

void myISR() {
    x = 1;
}

int setup() {
    // Configure PORTC, bit 5 to be digital I/O
    PORTC_PCR5 = PORT_PCR_MUX(0x1);
    // Configure bit 5 to be an output
    GPIOC_PDDR = 0x20;

    // Configure the timer
    Timer1.initialize(200000); // in usec
    Timer1.attachInterrupt(myISR);
    Timer1.start();
}

loop() {
    if(x == 1) { // equals?
        x = 0;
        GPIOC_PDOR ^= 0x20; // XOR
    }
}
```

31. (6 points) What is the duty cycle of the signal at PORT C, pin 5?  
A. 0%   B. 25%   C. 50%   D. 100%   E. Answer not shown
  
32. (6 points) What is the interrupt frequency?  
A. 0Hz   B. 2.5Hz   C. 5Hz   D. 200,000Hz   E. Answer not shown
  
33. (6 points) What is the frequency of the signal at PORT C, pin 5?  
A. 0Hz   B. 2.5Hz   C. 5Hz   D. 200,000Hz   E. Answer not shown
  
34. (5 points) This is an example of what type of interrupt?  
A. Externally-generated   B. **Internally-generated**



Part VII. Finite State Machines

37. (25 points) Consider a FSM that will receive input from a keypad and lock/unlock a door:
1. The keypad has digits 0...9.
  2. On power up, the door is locked.
  3. As soon as the sequence 1, 1, 3, 8 is entered, the door must be unlocked.
  4. Once in a not locked state, when 0 is entered, the door is immediately locked and the FSM returns to a state in which it is waiting for a code.
  5. As soon as the sequence 1, 1, 3, 0 is entered, the FSM sounds an alarm and the door is permanently locked.
  6. Sequences other than the two listed above are ignored.
  7. The events are: 0, 1, ...9.
  8. The actions are: LOCK, UNLOCK, ALARM and none (X).

Draw the diagram that describes the behavior of this FSM.

# Door Lock Problem

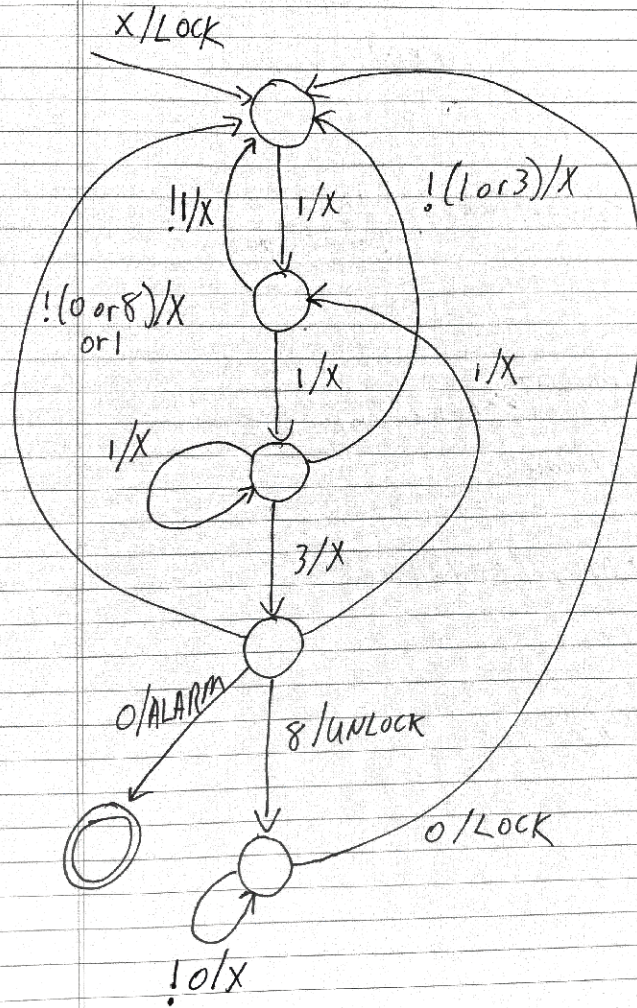

Solution:

38. (25 points) Consider a plant watering control system for your garden, with the properties as follows:

1. The plant must be watered from 8:00 - 8:10am every day, except if rain has been detected in the 36 hours prior to 8:00am.
2. The rain sensor is not affected by the automatic watering system.
3. A function  $getTime()$  returns the number of seconds since January 1st, 1970. You may assume that the integer representation is large enough so that the value has not wrapped around (and will not in the near future).
4. A function  $is8am(t)$  returns **true** if  $t$  is in the range of 8:00 and 8:01am.
5. You may introduce a state variable that stores time.

List the FSM actions and events, and draw the FSM that will control the produce the above behavior with the listed constraints.

