

AME 3623 Real-Time Embedded Systems
Midterm
March 7, 2019

General instructions:

- Please wait to open this exam booklet until you are told to do so.
- This examination booklet has 10 pages. You also have been issued a bubble sheet.
- Write your name, university ID number and date, and sign your name below. Also, write your name and ID number on your bubble sheet, and fill in the bubbles for your ID.
- The exam is closed book, notes and electronic devices. The exception is that you may have one page of personal notes (double sided).
- The exam is worth a total of 137 points (and 10% of your final grade).
- You have 1.25 hours to complete the exam. Be a smart test taker: if you get stuck on one problem go on to the next one.
- Use your bubble sheet to answer all multiple-choice questions. Make sure that the question number and the bubble row number match when you are answering each question.

On my honor, I affirm that I have neither given nor received inappropriate aid in the completion of this exam.

Signature: _____

Name: _____

ID Number: _____

Date: _____

Question	Points	Score
Binary Representations and Mathematical Operators	28	
Circuits	36	
Digital/Analog Systems	12	
Finite State Machines	15	
Digital I/O	24	
Serial Processing	10	
Motor Control	12	
Total:	137	

Part I. Binary Representations and Mathematical Operators

1. (4 points) What is the hexadecimal representation of c after the following code is executed?

```
uint8_t a = 0x28;
uint8_t b = 1 << 4;
uint8_t c = b ^ a; // XOR
```

- A. $0x8$ B. $0x18$ C. $0x29$ D. $0x38$ E. Answer not shown

2. (4 points) What is the binary representation of a after the following code is executed?

```
uint8_t a = 31;
```

- A. 0001 0001 B. 0001 1111 C. 0010 0000 D. 0011 0001
E. Answer not shown

3. (4 points) What is the hexadecimal representation of c after the following code is executed?

```
uint8_t a = 0x27;
uint8_t b = 0x42;
uint8_t c = a || b;
```

- A. $0x0$ B. $0x1$ C. $0x10$ D. $0x67$ E. Answer not shown

4. (4 points) What is the decimal representation of d after the following code is executed?

```
uint8_t a = 0x32;
uint8_t b = a >> 2;
uint8_t c = b << 5;
uint8_t d = c >> 3;
```

- A. 0001 0000 B. 0011 0000 C. 0011 0010 D. 0110 0100
E. Answer not shown

5. (4 points) What is the hexadecimal value of c after the following code is executed?

```
uint8_t a = 0x32;
uint8_t b = 0xE7;
uint8_t c = a & b
```

- A. $0x0$ B. $0x22$ C. $0x32$ D. $0xF7$ E. Answer not shown

6. (4 points) What is the decimal representation for the binary digits 0110 0101?
A. 53 B. 101 C. 106 D. 201 E. Answer not shown
7. (4 points) What is the binary representation of c after the following code is executed?

```
uint16_t a = 0x3F;  
uint16_t b = a + 10;  
uint16_t c = b << 2;;
```

- A. 0000 0001 0010 B. 0000 0001 0011 C. 0001 0010 0100 D. 0001 0011 1100
E. Answer not shown

Part II. Circuits

Consider the following circuit:

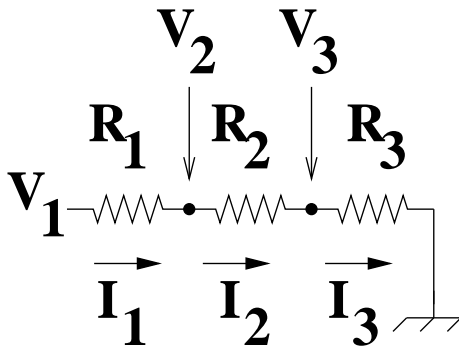

Assume $R_1 = 100 \Omega$, $R_2 = 200 \Omega$, $R_3 = 300 \Omega$.

8. (6 points) If $V_1 = 6V$, what is V_2 ?
A. 2 V B. 3 V C. 5 V D. 6 V E. Answer not shown

9. (6 points) If $V_3 = 10V$, what is V_1 ?
A. 0 V B. 5 V C. 10 V D. 20 V E. Answer not shown

10. (6 points) If $V_1 = -3V$, what is I_3 ?
A. -10 mA B. -5 mA C. 5 mA D. 10 mA E. Answer not shown

Consider the following circuit:

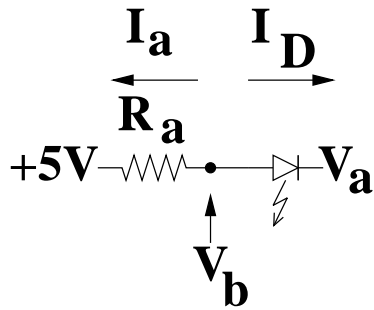

Assume $R_a = 100\Omega$ and $V_f = 1V$.

11. (6 points) If $V_b = 4\text{ V}$, what is I_D ?
 A. -10 mA B. -1 mA C. 0 mA D. 10 mA E. Answer not shown

12. (6 points) If $V_a = 7\text{ V}$, what is I_a ?
 A. 0 mA B. 10 mA C. 20 mA D. 30 mA E. Answer not shown

13. (6 points) If $V_a = 1\text{ V}$, what is V_b ?
 A. 0 V B. 1 V C. 2 V D. 3 V E. Answer not shown

Part III. Digital/Analog Systems

Assume an 4-bit digital-to-analog converter that has a range of 0 to 5 V (each digital pin outputs 0 or 5 V). The design follows the design that we did in class for the 2 and 8-bit cases:

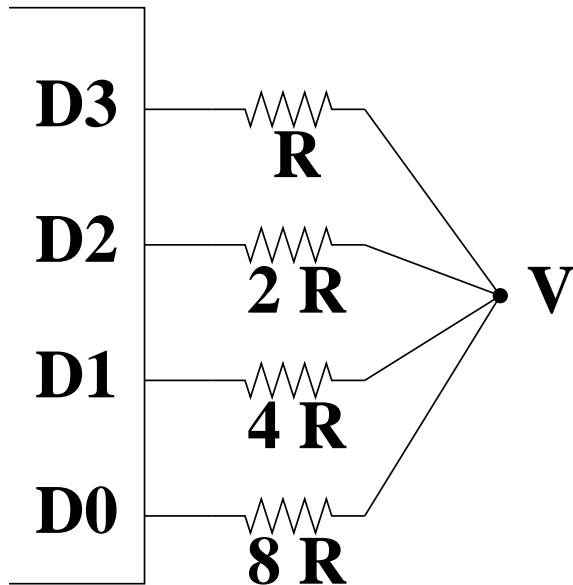

14. (6 points) What is the resolution of this converter (i.e., how much does the voltage change with one increment of the digital value)?
A. $1/15 V$ B. $1/3 V$ C. $1/2 V$ D. $1 V$ E. Answer not shown
15. (6 points) Given an output of $D[3,2,1,0] = [0, 1, 1, 0]$, what is V ?
A. $6/51 V$ B. $2 V$ C. $30/7 V$ D. $10/3 V$ E. Answer not shown

Part IV. Finite State Machines

Consider the following FSM:

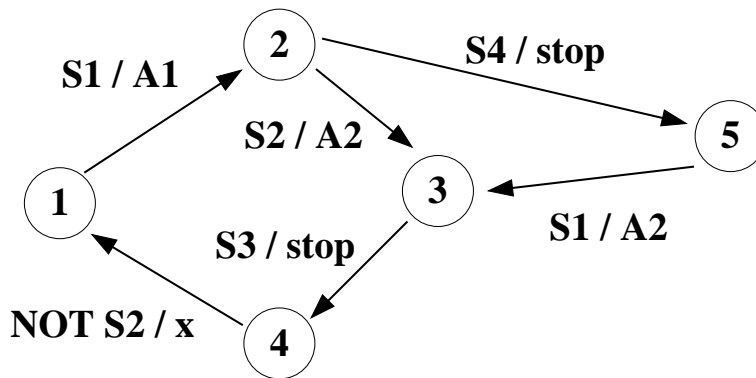

The actions are: A1, A2, stop.

The events are: S1, S2, S3, S4 and NOT S2 (S2 not triggered).

Notes:

- S1 is a button press and therefore is “true” for a very brief period of time.
- S2 is a safety sensor and can be “true” for an extended period of time.
- Following action A1, event S4 will eventually happen (assume a delay).
- Following action A2, event S3 will eventually happen (assume a delay).

16. (5 points) Assuming that the initial state is **1** and that **S2 = True**. What state does the FSM stop in when **S1** is pressed?
A. 1 B. 2 C. 3 D. 4 E. 5
17. (5 points) Assuming that the initial state is **1** and that **S2 = False**. What state does the FSM stop in when **S1** is pressed?
A. 1 B. 2 C. 3 D. 4 E. 5
18. (5 points) Assuming that the initial state is **5** and that **S2 = False**. What state does the FSM stop in when **S1** is pressed?
A. 1 B. 2 C. 3 D. 4 E. 5

Part V. Digital I/O

Consider the following circuit and code:

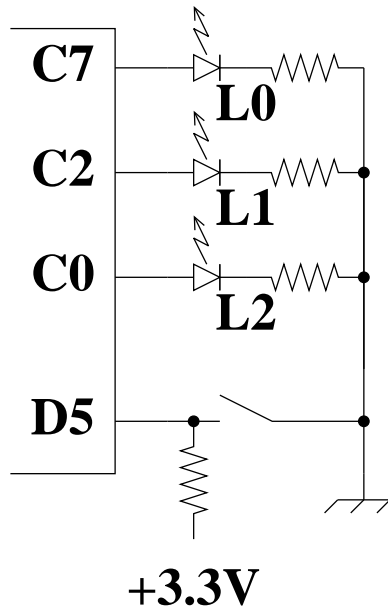

```

void setup()
{
  // You may assume that the pin
  // assignments are correct
  PORTC_PCR7 = PORT_PCR_MUX(0x1);
  PORTC_PCR2 = PORT_PCR_MUX(0x1);
  PORTC_PCR0 = PORT_PCR_MUX(0x1);
  PORTD_PCR5 = PORT_PCR_MUX(0x1);

  GPIOC_PDDR = 0x85;
  GPIOD_PDDR = 0x20;

  GPIOC_PDOR = 0;
}

void loop()
{
  if(GPIOD_PDIR & 32) {
    // TOP
    GPIOC_PDOR = GPIOC_PDOR | 0x81;
    delay(20);
    GPIOC_PDOR = GPIOC_PDOR & ~0x80; // AND Not
    delay(30);
  } else {
    // BOTTOM
    GPIOC_PDOR = GPIOC_PDOR ^ 0x84; // XOR
    delay(100);
  }
}

```

19. (6 points) When the switch is closed, which section of code is executed?
A. TOP B. BOTTOM

20. (6 points) When the BOTTOM section of code is executed repeatedly, what is the duty cycle of L2?
A. 25% B. 33.33% C. 50% D. 75% E. Answer not shown

21. (6 points) When the TOP section of code is executed repeatedly, what is the flashing frequency of L0?
A. 2 Hz B. 5 Hz C. 20 Hz D. 50 Hz E. Answer not shown

22. (6 points) When the TOP section of code is executed repeatedly, what is the duty cycle of L2?
A. 20% B. 40% C. 50% D. 100% E. Answer not shown

Part VI. Serial Processing

Consider the following code block:

```
1  uint32_t get_hex ()
2  {
3      char c;
4      uint32_t value = 0;
5
6      while(1)
7      {
8          c = Serial.read();
9          if(c >= '0' && c <= '9')
10         {
11             value = value * 16 + c - '0';
12         }
13         else if(c >= 'A' && c <= 'F')
14         {
15             value = value * 16 + c - 'A';
16         }
17         else
18         {
19             return(value);
20         }
21     }
22 }
```

23. (6 points) The above function is to interpret a sequence of hexadecimal digits ([0, 1, ... ,9, A, ..., F]) and return the corresponding value. This function will continue to accept digits until a non-hex character is received.
- For example: '2', '2', 'x' will result in the value 34 being returned. And the sequence '1', 'A', ']' will result in the value 26 being returned.
- On which line is the bug?
- A. 9 B. 11 C. 13 D. 15 E. There is no bug
24. (4 points) What is the maximum number of digits that can be accepted before we exceed the storage capacity of the **value** variable?
- A. 4 B. 8 C. 16 D. 32 E. Answer not shown

Part VII. Motor Control

The following is a diagram of an H-bridge circuit:

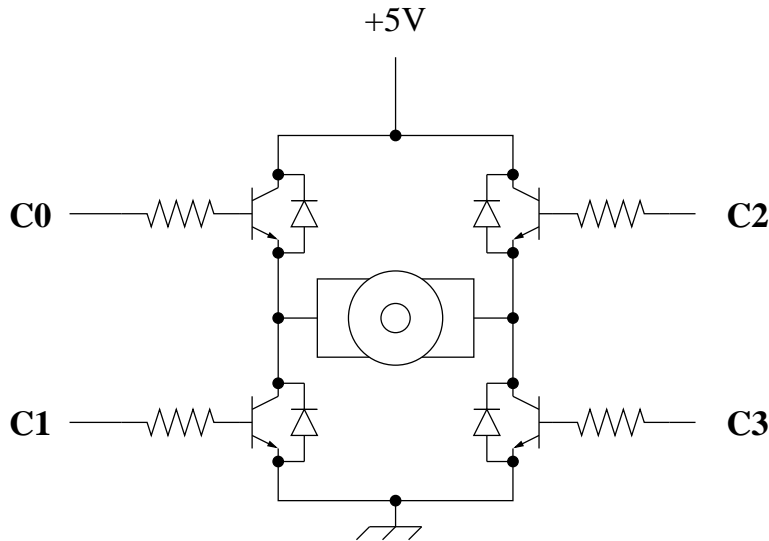

25. (4 points) Which of the following corresponds to torque being generated by the motor?
- A. $C[0, 1, 2, 3] = [0, 0, 0, 0]$ B. $C[0, 1, 2, 3] = [0, 0, 1, 1]$
 C. $C[0, 1, 2, 3] = [0, 1, 0, 1]$ D. $C[0, 1, 2, 3] = [0, 1, 1, 0]$
 E. Answer not shown
26. (4 points) True or False? Torque is proportional to current flow through the motor.
- A. True B. False
27. (4 points) Which of the following corresponds to dynamically braking the motor?
- A. $C[0, 1, 2, 3] = [0, 0, 0, 0]$ B. $C[0, 1, 2, 3] = [0, 0, 1, 1]$
 C. $C[0, 1, 2, 3] = [0, 1, 0, 1]$ D. $C[0, 1, 2, 3] = [0, 1, 1, 0]$
 E. Answer not shown