

AME 3623 Real-Time Embedded Systems
Midterm
March 5, 2020

General instructions:

- Please wait to open this exam booklet until you are told to do so.
- This examination booklet has 8 pages. You also have been issued a bubble sheet.
- Write your name, university ID number and date, and sign your name below. Also, write your name and ID number on your bubble sheet, and fill in the bubbles for your ID.
- The exam is closed book, notes and electronic devices. The exception is that you may have one page of personal notes (double sided).
- The exam is worth a total of 137 points (and 10% of your final grade).
- You have 1.25 hours to complete the exam. Be a smart test taker: if you get stuck on one problem go on to the next one.
- Use your bubble sheet to answer all multiple-choice questions. Make sure that the question number and the bubble row number match when you are answering each question.

On my honor, I affirm that I have neither given nor received inappropriate aid in the completion of this exam.

Signature: _____

Name: _____

ID Number: _____

Date: _____

Question	Points	Score
Binary Representations and Mathematical Operators	28	
Circuits	30	
Digital/Analog Systems	22	
Finite State Machines	15	
Digital I/O	30	
Motor Control	12	
Total:	137	

Part I. Binary Representations and Mathematical Operators

1. (4 points) What is the hexadecimal value of c after the following code is executed?

```
uint8_t a = 0x17;  
uint8_t b = 0xBA;  
uint8_t c = a & b
```

A. 0x0 B. 0x1 **C. 0x12** D. 0xBF E. Answer not shown

2. (4 points) What is the decimal representation for the binary digits 1010 0101?

A. 45 B. 85 **C. 165** D. 169 E. Answer not shown

3. (4 points) What is the binary representation of a after the following code is executed?

```
uint8_t a = 0x31;
```

A. 0000 1111 B. 0001 1001 C. 0001 1111 **D. 0011 0001**
E. Answer not shown

4. (4 points) What is the hexadecimal representation of c after the following code is executed?

```
uint8_t a = 0x28;  
uint8_t b = 0xB3;  
uint8_t c = b ^ a;    // XOR
```

A. 0x1 B. 0x20 **C. 0x9B** D. BB E. Answer not shown

5. (4 points) What is the hexadecimal representation of c after the following code is executed?

```
uint8_t a = 0x42;  
uint8_t b = 0x27;  
uint8_t c = a | b;
```

A. 0x0 B. 0x1 C. 0x10 **D. 0x67** E. Answer not shown

6. (4 points) What is the decimal representation of d after the following code is executed?

```
uint16_t a = 0x32;  
uint16_t b = a >> 2;  
uint16_t c = b << 5;  
uint16_t d = c >> 3;
```

- A. 0001 0000 **B. 0011 0000** C. 0011 0010 D. 0110 0100
E. Answer not shown

7. (4 points) What is the hexadecimal representation of c after the following code is executed?

```
uint16_t a = 0x4B;  
uint16_t b = a + 10;  
uint16_t c = b / 2;
```

- A. 0x2A** B. 0x2D C. 0x5B D. 0xB6 E. Answer not shown

Part II. Circuits

Consider the following circuit:

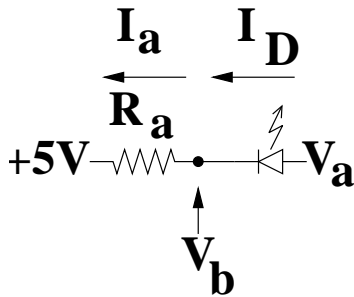

Assume $R_a = 200\Omega$ and $V_f = 2V$.

8. (6 points) If $V_b = 7\text{ V}$, what is I_D ?
 A. -10 mA B. -1 mA C. 0 mA **D. 10 mA** E. Answer not shown
9. (6 points) If $V_a = 8\text{ V}$, what is I_a ?
 A. 0 mA **B. 5 mA** C. 10 mA D. 15 mA E. Answer not shown
10. (6 points) If $V_a = 6\text{ V}$, what is V_b ?
 A. 0 V B. 4 V **C. 5 V** D. 6 V E. Answer not shown

Consider the following circuit:

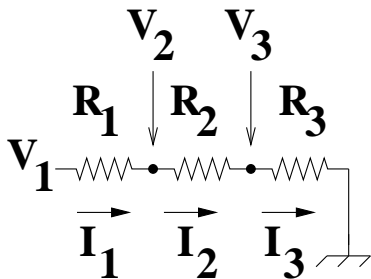

Assume $R_1 = 200\Omega$, $R_2 = 100\Omega$, $R_3 = 200\Omega$.

11. (6 points) If $V_3 = 4V$, what is I_3 ?
 A. 0 mA B. 10 mA **C. 20 mA** D. 40 mA E. Answer not shown
12. (6 points) If $V_3 = -10V$, what is V_1 ?
A. -25 V B. -10 V C. 5 V D. 15 V E. Answer not shown

Part III. Digital/Analog Systems

13. (4 points) Assume a 3-bit digital-to-analog converter that has a range of 0 to 5V. What is the resolution of this converter (i.e., how much does the voltage change with one increment of the digital value)?
A. $1/7 V$ B. $1/3 V$ C. $1/2 V$ **D. $5/7 V$** E. Answer not shown
14. (6 points) For the same digital-to-analog converter, given a digital value of $D[2,1,0] = [1, 0, 1]$, what is V ?
A. $1/15 V$ B. $1/7 V$ C. $25/15 V$ **D. $25/7 V$** E. Answer not shown
15. (6 points) Assume a 2-bit digital-to-analog converter that has a range of 0 to 3.3V. What is the voltage that corresponds to a digital value of $D = 2$?
A. 0 V B. 1.1 V **C. 2.2 V** D. 3.3 V E. Answer not shown
16. (6 points) Assume a 4-bit analog-to-digital converter that uses the successive approximation algorithm, and has a range of 0 to 5V. If $V_{in} = 2.1 V$, what digital value does the successive approximation algorithm choose?
A. 0110 B. 0111 C. 1000 D. 1001 E. Answer not shown

Part IV. Finite State Machines

Consider the following FSM:

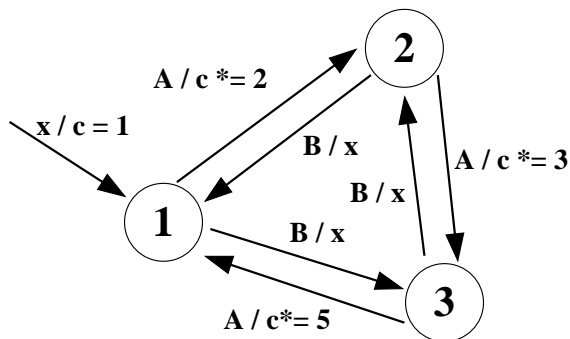

The actions are either a mathematical operation or nothing (x)

The events are: A, B

17. (5 points) Assume that the FSM is initialized and then receives the following events: A, A. What is the value of c ?
A. 1 B. 2 C. 4 **D. 6** E. Answer not shown

18. (5 points) Assume that the FSM is initialized and then receives the following events: A, B, A, A. What is the value of c ?
A. 1 B. 8 **C. 12** D. 30 E. Answer not shown

19. (5 points) Assume that the FSM is initialized and then receives the following events: A, A, B, A, A. What is the value of c ?
A. 6 B. 30 C. 60 **D. 90** E. Answer not shown

Part V. Digital I/O

Consider the following circuit and code:

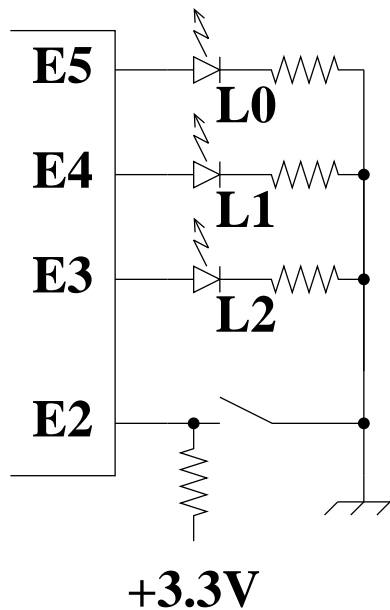

```

void setup()
{
  PORTE_PCR5 = PORT_PCR_MUX(0x1);
  PORTE_PCR4 = PORT_PCR_MUX(0x1);
  PORTE_PCR3 = PORT_PCR_MUX(0x1);
  PORTE_PCR2 = PORT_PCR_MUX(0x1);

  GPIOE_PDDR = ???;

  GPIOE_PDOR = 0;
}

void loop()
{
  if (GPIOE_PDIR & MASK) {
    GPIOE_PDOR = GPIOE_PDOR ^ 0xF0; // XOR
    delay(50);
  } else {
    GPIOE_PDOR = GPIOE_PDOR | 0x3C;
    delay(70);
    GPIOE_PDOR = GPIOE_PDOR & ~0x34; // AND Not
    delay(30);
  }
}

```

20. (6 points) What is the correct initialization of GPIOE_PDDR?
 A. 0x38 B. 0x3C C. 0x70 D. 0x78 E. Answer not shown

21. (6 points) In order for the code to respond to the switch, what should the value of MASK be?
 A. 0x2 B. 0x4 C. 0x8 D. 0xFF E. Answer not shown

22. (6 points) When the switch is opened for an extended period of time, what is the flashing frequency of L0? Assume that the input and output pins and MASK are configured correctly.
 A. 10 Hz B. 20 Hz C. 50 Hz D. 70 Hz E. Answer not shown

23. (6 points) When the switch is closed for an extended period of time, what is the duty cycle of L0? Assume that the input and output pins and MASK are configured correctly.
 A. 30 % B. 35 % C. 50 % D. 70 % E. Answer not shown

24. (6 points) When the switch is closed for an extended period of time, what is the flashing frequency of L2? Assume that the input and output pins and MASK are configured correctly.
 A. 5 Hz B. 7 Hz C. 10 Hz D. 20 Hz E. Answer not shown

Part VI. Motor Control

The following is a diagram of an H-bridge circuit:

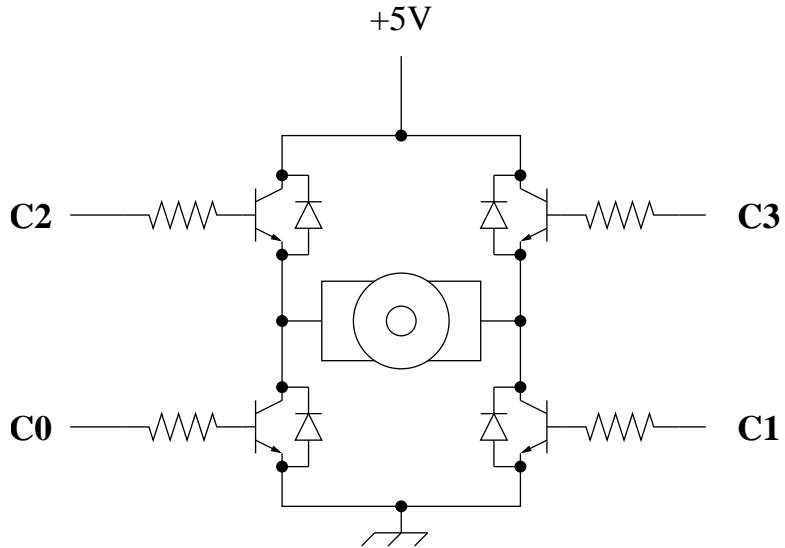

25. (4 points) Which of the following corresponds to torque being generated by the motor?
- A. $C[3, 2, 1, 0] = [0, 0, 0, 0]$ B. $C[3, 2, 1, 0] = [0, 0, 1, 1]$
 C. $C[3, 2, 1, 0] = [0, 1, 0, 1]$ D. $C[3, 2, 1, 0] = [0, 1, 1, 0]$
 E. Answer not shown
26. (4 points) Which of the following corresponds to a short circuit?
- A. $C[3, 2, 1, 0] = [0, 0, 0, 0]$ B. $C[3, 2, 1, 0] = [0, 0, 1, 1]$
 C. $C[3, 2, 1, 0] = [0, 1, 0, 1]$ D. $C[3, 2, 1, 0] = [0, 1, 1, 0]$
 E. Answer not shown
27. (4 points) True or False? A free spinning brushed motor induces a potential difference between its two brushes.
- A. **True** B. False